

THREE-PHASE ELECTRIC MOTORS - SERIE AT DIMENSIONS - IM B3

IM B3

SECTION A-A

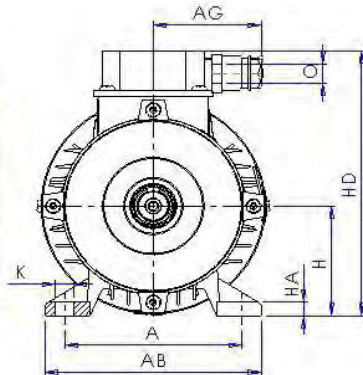
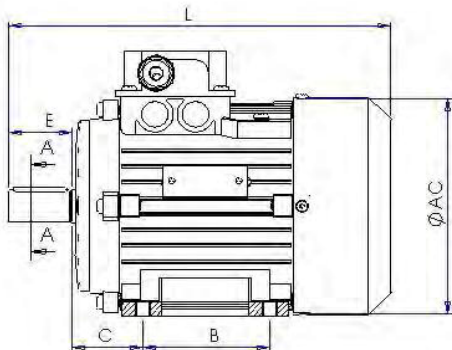
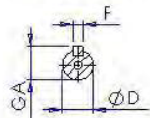

TYPE	Dimensions [mm]											Shaft				
	A	B	C	HA	AB	AC	AG	H	HD	K	L	O	D	E	GA	F
AT 90 S	140	100	56	13	184	178	85	90	222	10	308	M20	24	50	27	8
AT 90 L		125									333					
AT 100 L	160	140	63	15	200	196	100	240	112	262	12	378	28	60	31	8
AT 112 M	190		70		220	218										
AT 132 S	216	210	89	20	260	258	95	132	310	15	450	M25	38	80	41	10
AT 160 M	254										575					
AT 16 L	279	254	108	24	318	284	110	160	370	15	605	M32	42	110	46	12
AT 180 M		241									656					
AT 180 L	279	706	121	20	350	321	130	180	395	15		706	48	110	51.5	14